

Parts List					
ITEM	QTY	PART No.	TITLE	WEBLINK	
2	1	BB3254	2,7kNm Class 4 EI Torque Tool V2	N/A	
3	1	BB2985	ETT Control PC wGUI Software and Pelicase	N/A	
3.1	1	900279	GUI Software for LTT HardWare 2C Revision 2,9991	N/A	
3.2	1	103650	ThinkPad Lenovo	N/A	
3.3	1	102857	Computer Mouse	N/A	
3.4	1	101817	Pelicase 1495D	N/A	
3.5	1	100687	Moxa UPort 1150I	N/A	
4	1	BB1086	Alu Box 415L incl. Foams	N/A	
5	1	BA7297	Class 4 Interface Socket Low Torque	<a href="http://e-sea.bluelogic.no/main.aspx?page=article&amp;artno=BA7297">http://e-sea.bluelogic.no/main.aspx?page=article&amp;artno=BA7297</a>	
6	1	BA6615	Class 3 Interface Socket	N/A	
7	1	BA2951	Class 1 & 2 Interface Socket	<a href="http://e-sea.bluelogic.no/main.aspx?page=article&amp;artno=BA2951">http://e-sea.bluelogic.no/main.aspx?page=article&amp;artno=BA2951</a>	
8	1	600144-TD-0003	Operation and Maintenance Manual Electric Torque Tool Class 1 - 4	N/A	
9	1	102860	Burton Dummy	N/A	
10	1	102354	Burton Test Cable	N/A	
11	1	100499	Burton Pigtail	N/A	

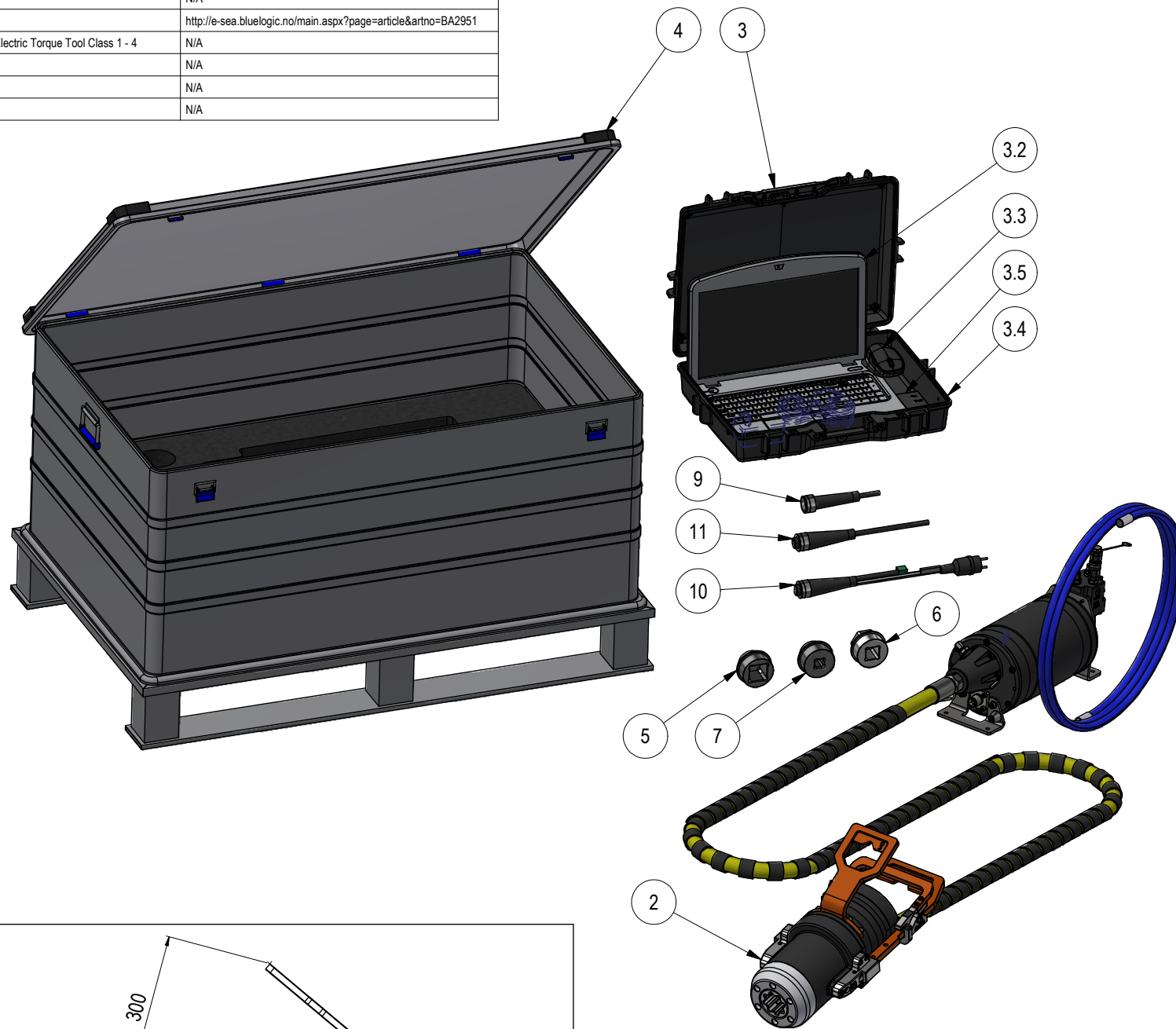

NOTE: 1  
DESIGN CODE:  
ISO 13628-8

NOTE: 2  
TECHNICAL CLASSIFICATION:  
Article Type: 008-Actuation  
Main Group: 8.01. ISO 1 to 4 Actuation  
Intermediate Group: 8.44.01. Tool  
Sub Group: 8.44.114.02. Intervention

NOTE: 3  
INTERFACE INFORMATION:  
Pressure Rating Bar: 3000m  
Design Water Depth: N/A  
Material: Hard Anodize Aluminium  
Weight in Air: 55 kg  
Volume: 151,29 dm<sup>3</sup>  
Surface Area: 244604 cm<sup>2</sup>  
Hydraulic: N/A  
Mechanical: N/A  
Electrical: 110-250 VAC / 145-350 VDC  
Com. & Protocol: RS232

NOTE: 4  
ADDITIONAL INFORMATION:  
Complete Class 1-4 Electrical Torque Tool System prepared for offshore use and operation, includes EI Torque Tool, Control Canister, cables, class 2 and 4 sockets and control pc.

The Blue Logic Class 1-4 Electrical Torque Tool (ELTT) is a module based, compact, flexible and robust precision tool for operation in all Subsea and ROV applications. The system combines all known advantages from a hydraulic torque tool system with the technology and advantages available from a modern servo based electrical controlled drive system. The included class 4 and class 2 interface sockets are easy to change on deck prior to deployment. The control system will automatically, detect socket and tool gear ratio and automatically switch between Low torque and High torque mode. The different sockets will automatically interface the gear system to utilize the optimal gear ration and power/speed utilization. The ELTT is designed for operation on ROV's with minimum 5-10A 110 VAC of continuous power available. Max allowed power consumption can be limited in the ELTT control system setup. Max continuous current consumption is 20A. The tool communicates through RS232 protocol. The ELTT is connected to the ROV thru a 3,5mtr. oil filled yellow umbilical connected to an electrical power control module mounted on the ROV

The system is delivered in an aluminum transport box size 1182x782x500 for onshore and offshore handling.

\*RS485 Optional

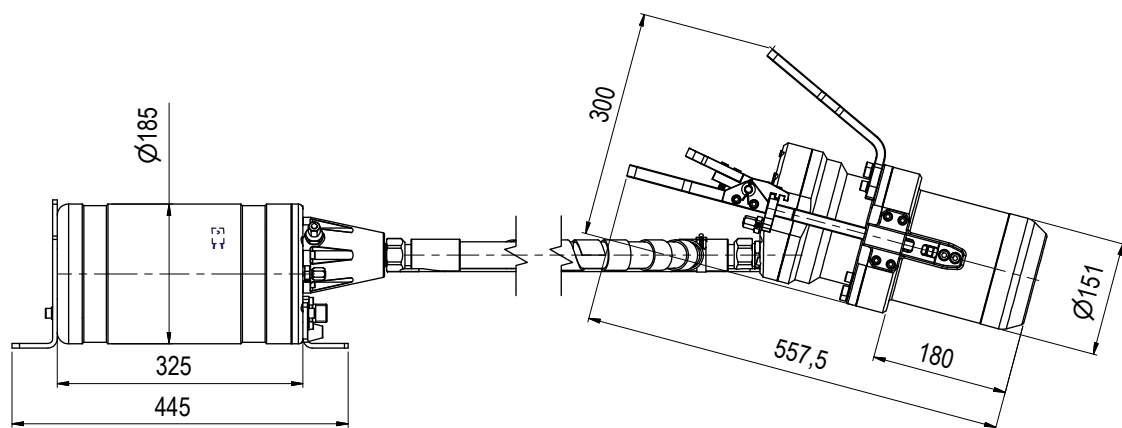

08	10.2.2026	9-IFU (Issued for Use)		WTJ	LGH	WTJ
07	13.11.2024	9-IFU (Issued for Use)		WTJ	LGH	WTJ
06	8.11.2023	9-IFU (Issued for Use)		WTJ	LGH	WTJ
05	10.10.2023	9-IFU (Issued for Use)		WTJ	LGH	KHA
Rev.	Date	Reason for issue	Revision change	Made	Chk'd	Appr.

**BLUE LOGIC**

This Drawing is the Property of Blue Logic AS © and must Not be Loaned, Reproduced or Transferred to others without written Permission

Dwg Scale:  
NTS  
Dwg Proj:  
Dwg Format:  
A3

Drawing title:  
2,7kNm Torque Tool Kit

Drawing number:  
BB3306

Rev:  
08